

Industrial IoT PAC Controller HX Series

HITACHI

Inspire the Next



EtherNet/IP



EtherCAT



PROFIBUS

PROFINET

DeviceNet

Automation Solutions by Hitachi

HX Series IoT Controller

The Hitachi HX series PAC Controller combines powerful features and efficiency to meet the demands of a global supply chain in manufacturing industries. In addition, HX series is already prepared for the next generation requirements in automation thanks to its IoT capabilities. Manufacturing & service innovations can be achieved with integrated functions and seamless connectivity from field machine level to cloud services.

Open standards

The Hitachi HX Series supports global manufacturing by standardized programming with 5 programming languages compatible with the IEC61131-3 international standard. The integrated EtherCAT and PROFINET master function (industrial open network) enables interconnection of a wide range of devices. Seamless data transfer from field level to cloud is achieved via OPC-Unified Architecture.

Improved processing speed

Through the effective combination of the recently developed high-performance CPU with CODESYS software, Hitachi provides sequential control (logic) and motion control on one CPU platform with very fast execution speed.

Simple & easy design environment

Next generation HX Series models are designed to provide the functionality as PAC Controller (Programmable Automation Controller) which is considered as evolution of both PLC & IPC. This enables users to achieve lower TCO (Total cost of ownership) through space reduction, lower installation, development and maintenance costs.



Communication Motion Control Sequential Control

Integrated network communication and core controls required for automated machines & production facilities

- Compatibility with IEC61131-3
- Local data logging by transmitting data to SD memory
- OPC-UA ERP coordination, MES connection, SCADA system
- Information system Ethernet (TCP / IP), IP communication, web supports
- EtherCAT motion control (Multi axes I/O control via EtherCAT)
- Supporting field networks*



*Some network requires combination use with master module.

General Overview

Flexible expansion

The functionality of the HX CPU can be expanded by adding various modules. The flexibility is given by the option to connect additional base racks using the connection port for cabinet expandability or using EtherCAT network to remote control base racks using a slave controller.

- Digital I/O
- Analogue I/O
- Special Function Modules





Model Line-up

	Hardware Specifications					Functional Features				
Standard Model HX-CP1S08	Program data memory 8 MB	Ethernet port 2	USB Host, device			EtherCAT master	PROFINET master			
Full Function Model HX-CP1H16	Program data memory 16 MB	Ethernet port 3	USB Host, device	SD Card	Serial comm. RS-485	EtherCAT master	PROFINET master	Web Visualization		
Motion Model HX-CP1S08M	Program data memory 8 MB	Ethernet port 2	USB Host, device			EtherCAT master	PROFINET master		Soft Motion	
CNC Motion Model HX-CP1H16M	Program data memory 16 MB	Ethernet port 3	USB Host, device	SD Card	Serial comm. RS-485	EtherCAT master	PROFINET master	Web Visualization	Soft Motion	CNC G-Code
Hybrid Model HXC-CP1H16	Program data memory 16 MB	Ethernet port 3	USB Host, device	SD Card	Serial comm. RS-485	EtherCAT master	PROFINET master	Web Visualization		C/C ++ program
Redundant Model HX-CP1H16R	Program data memory 16 MB	Ethernet port 3	USB Host, device	SD Card	Serial comm. RS-485	EtherCAT master	PROFINET master	Web Visualization		CPU Redundancy

Standard Features of all Models

Less maintenance costs

■ Battery-less design

Non-volatile memory is used for programming memory & data memory. The CPU can record manufacturing data without optional batteries to protect the data from sudden power failures.

■ Fan-less design

The CPU has no mechanical parts which need to be replaced.

Less costs for software development

- CODESYS – globally accepted, standardized programming software
- Easy to use for PLC beginners, computer system engineers etc.
- Variable names can be commonly used between PLC, HMI and SCADA



Data Protection

■ Block unauthorized access

- Detect / Protect unauthorized external access
- Block unauthorized remote login connection
- Prevent malicious data hacking

■ Control user access

- Detect / Protect unauthorized external access
- Block unauthorized remote login connection
- Prevent malicious data hacking

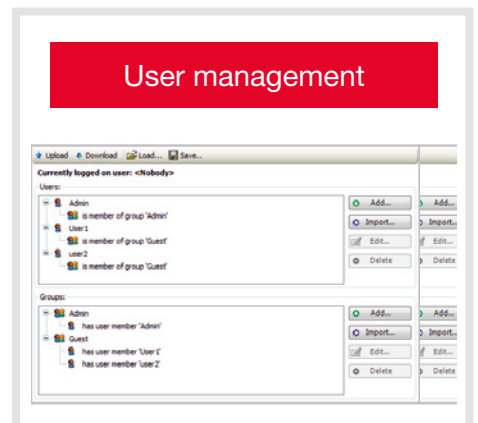
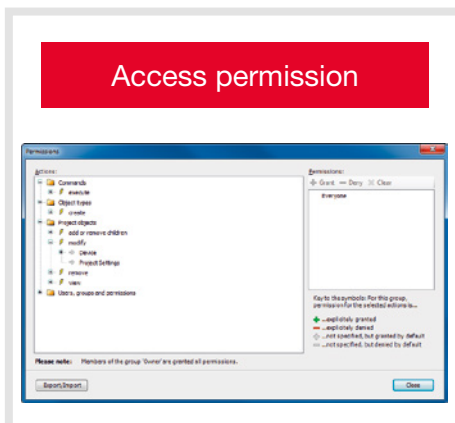

5 programming languages

- Advanced programming visualization (easy to read & understand)
- Flexible memory allocation (no need to allocate work memory address)
- Optimal language selection based on process requirements possible
- Library function which enables easy re-use of user programs

Ladder Logic Diagram (LD)

Recommended for interlock processing.

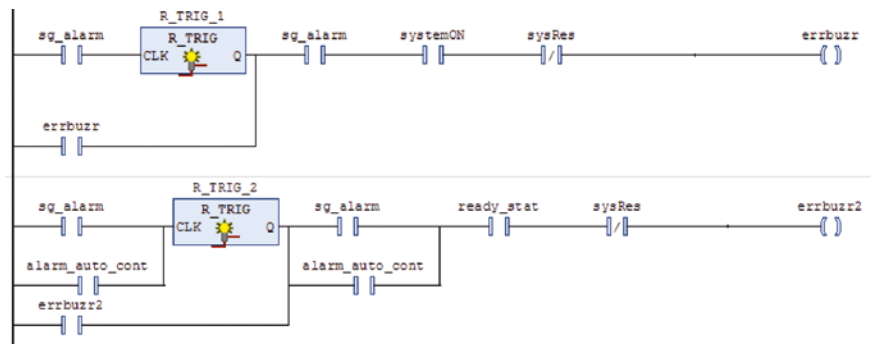

Function Block Diagram (FBD)

Graphical language easy to track command & data transfer between each function.

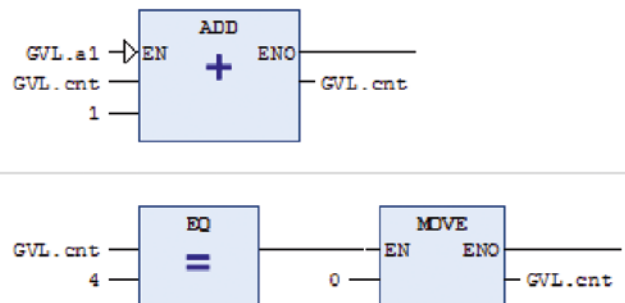

Structured Text (ST)

Ideal for programs having branch, repeat and calculation processes.

```

1  count_M3:=count_M3+1;
2  L2_wait_time (IN:=FALSE, PT:=T#3.6S);
3  L2_wait_time (IN:=TRUE);
4  FOR i:=0 TO count_I DO
5      K1_temp[i]:=B1_init; //Reset B1
6  END_FOR
7  IF count_Nmax <24 THEN
8      WHILE vxcount<10 DO
9          T1max:=125; //Max.=125 digC
10     END_WHILE
11 END_IF
12 B100status:=FALSE; //B100 complete

```

Instruction List (IL)

Mnemonic language. Best for the use of short programs and high speed calculation.

```

LD      sg_alarm
OR (    TON_1.Q
ANDN   doorclose
AND    alw_d_open
)
AND    ready_start
OR     lampcheck
ST     spare5
CAL    R_TRIG_1(
      CLK:= sg_alarm)
LD     R_TRIG_1.Q
OR     errbuzz
AND    sg_alarm

```

Sequential Function Chart (SFC)

Easy to show state transition.

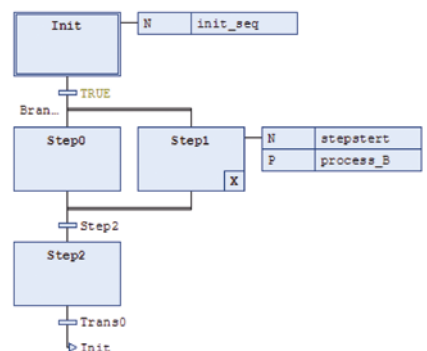

Features of Full Function Model



Large size data logging (SD Card)

Non-volatile memory is used for programming memory & data memory. The CPU can record manufacturing data without optional batteries to protect the data from sudden power failures.

Web visualisation (Monitoring via Web Browser)

Easy remote access to the controller's web server to monitor the application status without preparing a customized HMI. Potential cost reduction for hardware and on site resources through off site monitoring.

- Web server function prepared as standard
- No requirement of customized HMI
- Availability of monitoring via standard web browser
- Remote maintenance, diagnosis and control can be also achieved

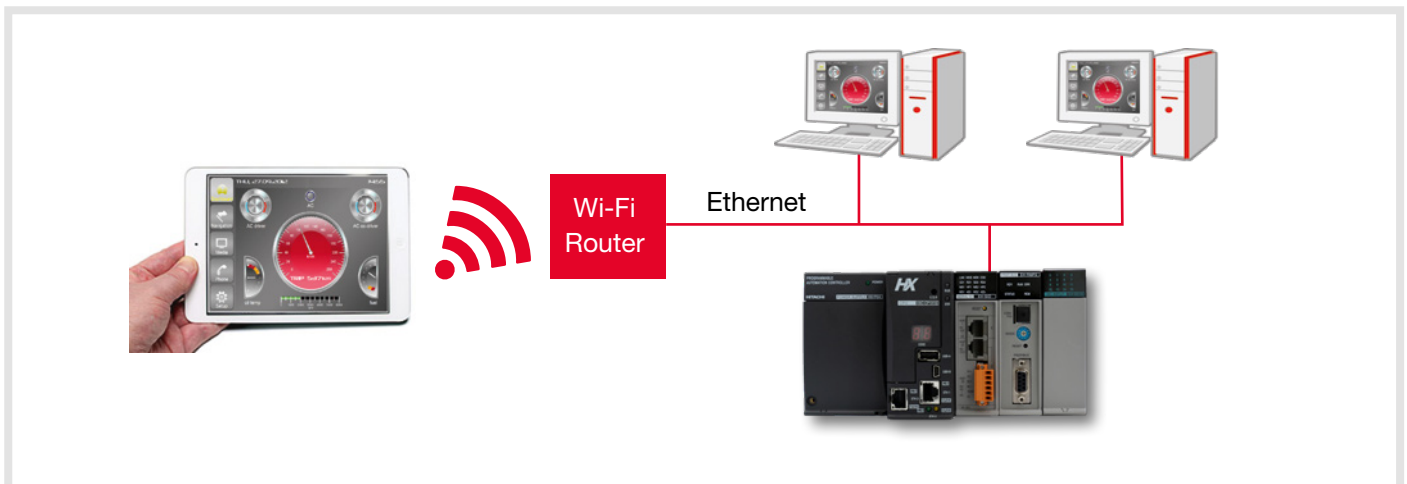

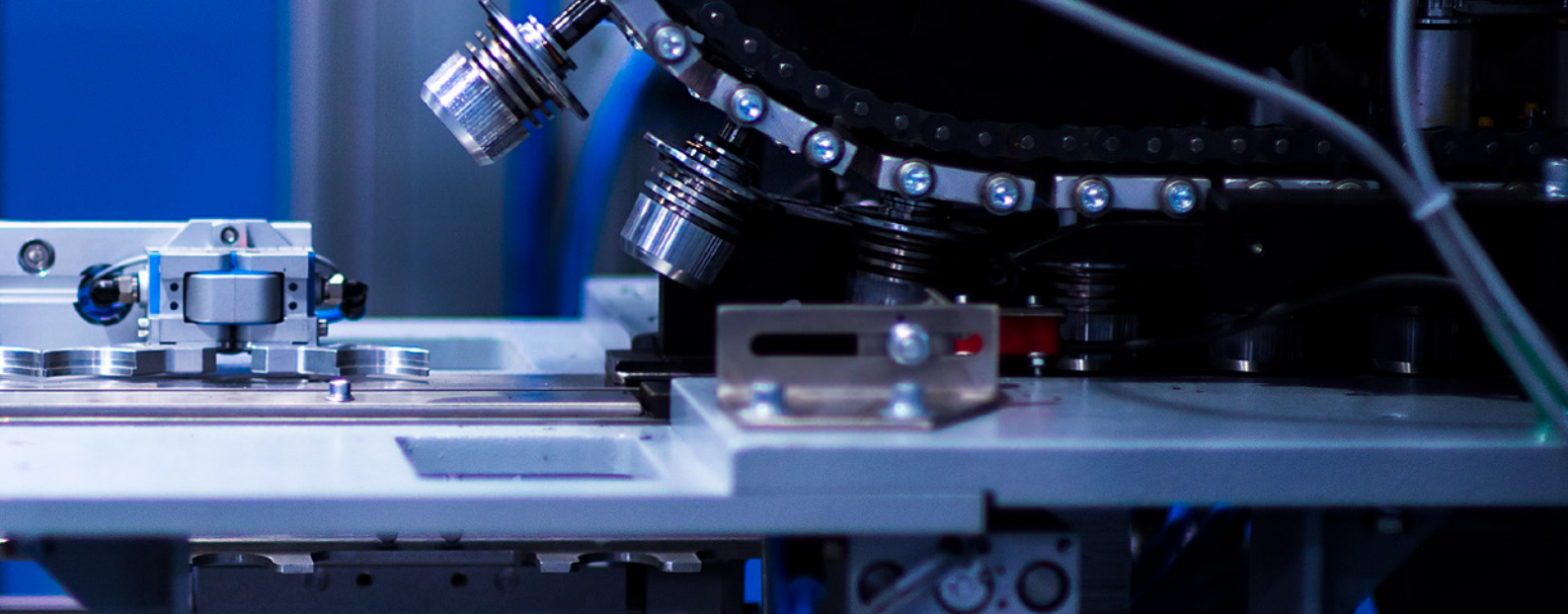

3 Ethernet ports as standard

- Various communication modes between master, controller and slave units by one CPU
- Depending on its connection combination, various topologies are possible

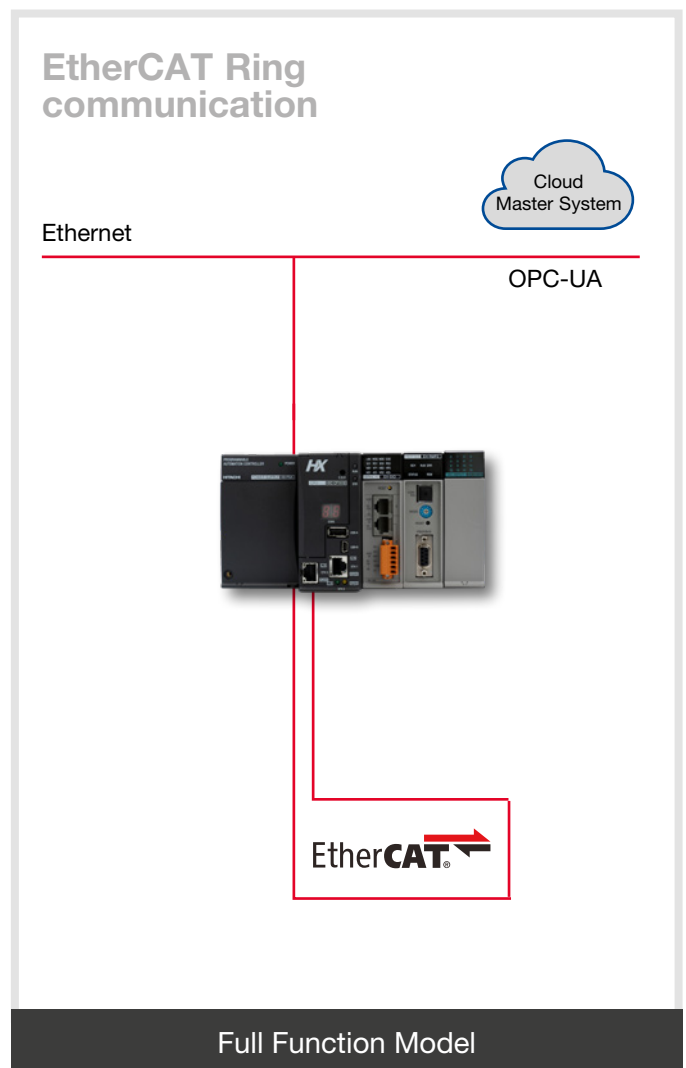
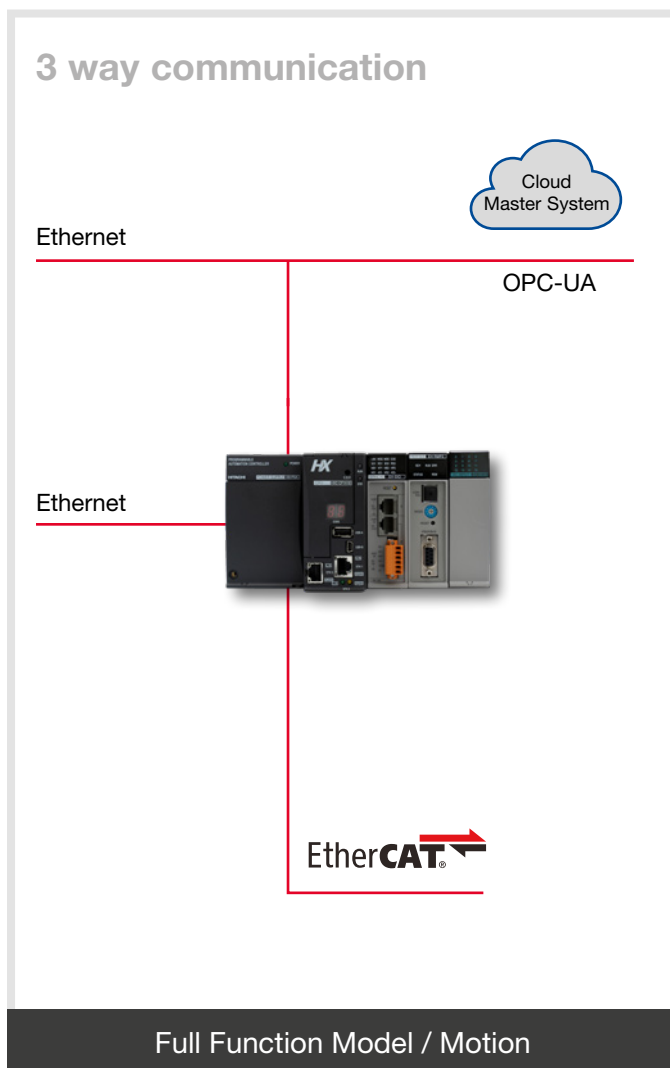



Redundant Model

HX-CP1H16R

- CPU redundancy by direct Ethernet based connection between 2 redundant CPU's
- Applications which require high availability can be realized
- Local and remote I/O can be used and will be controlled by the active CPU
- Continuous checking of active and stand-by CPU
- Additional 2 LAN ports are available for general purpose such as EtherCAT or communication to OPC clients

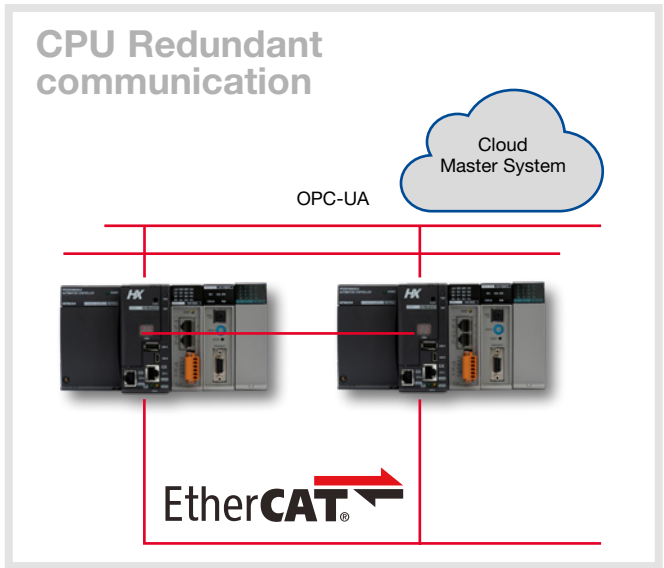

Motion Model & CNC Motion Model

HX-CP1S08M / HX-CP1H16M

PLCopen based Motion control function block

- Position, velocity & acceleration control for simple single axis or for synchronized control of multiple axes, using graphical editor prepared for electronic cam function
- Motion simulation with a virtual axis function
- Motion and logic on one CPU
- LAN port supports motion functionality
- A variety of slaves such as inverters or remote I/O may be controlled via EtherCAT
- On CNC Motion Model, a SoftMotion CNC package is available with multi axes coordinated functions for CNC & robots

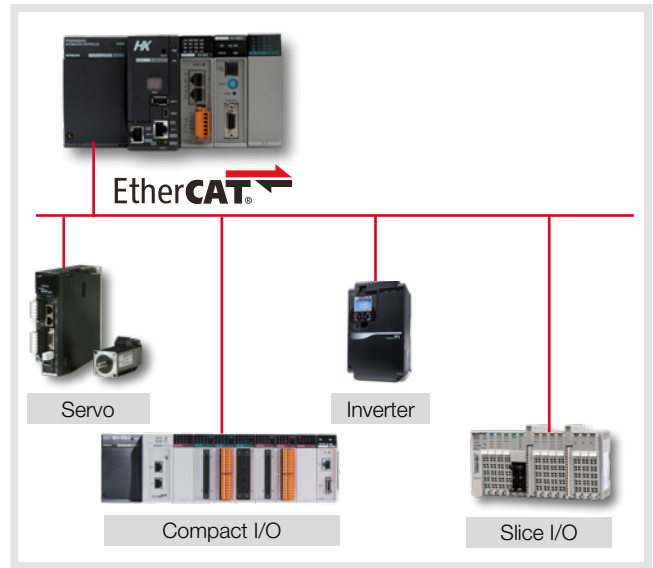

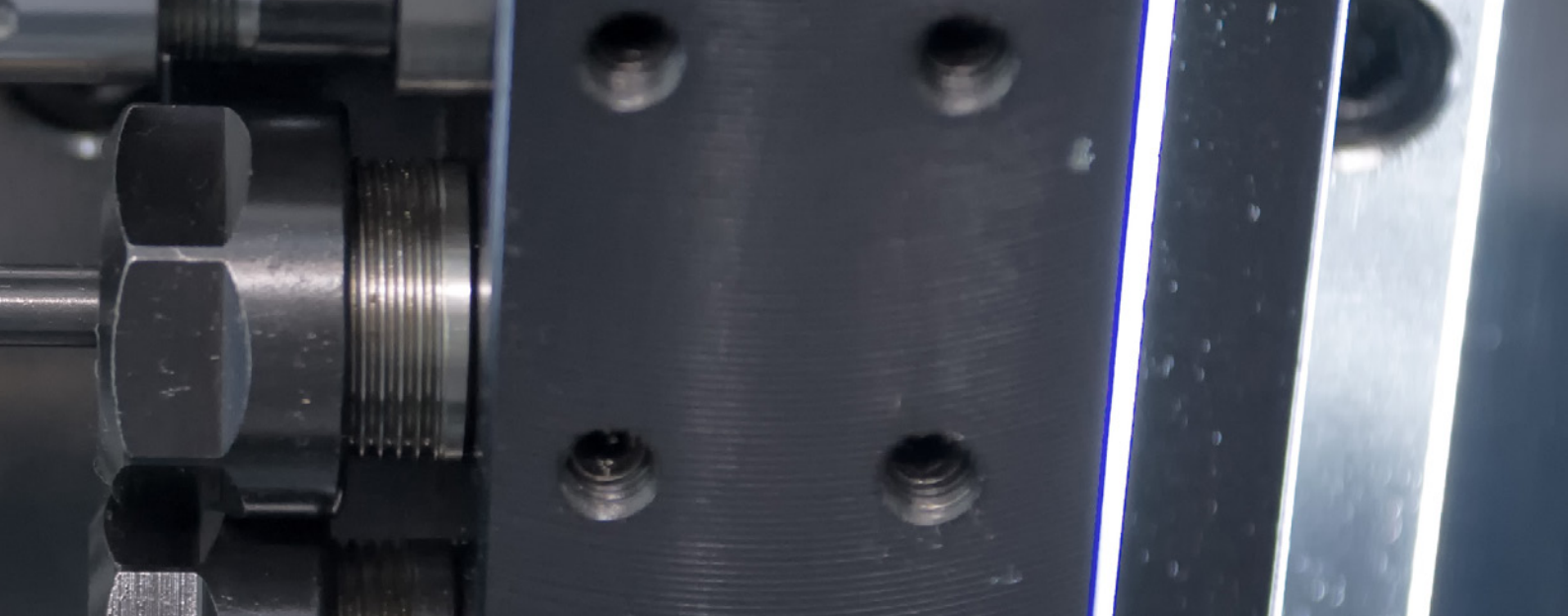

Function blocks for PLCopen based motion control

In addition to PTP position control in single axis use, interpolation and synchronized control of multiple axes, the HX Series enables speed and torque control in combination with feedback data.



Motion control applicable for PLCopen standard Single Axis Part I and II Master/Slave Axis (e.g. MC_CamIn, MC_GearIn, MC_Phasing etc.)

CAM editor

- Create cam table using the CAM editor

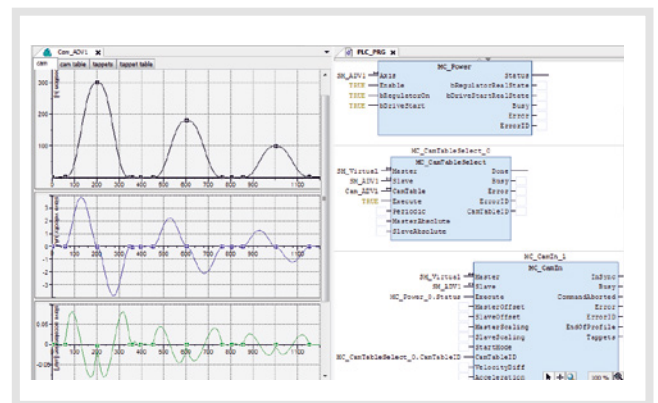

CNC (G code), available on CNC Motion Model only

- Trajectory control by G code. Possible to read out coordinates from DXF files. Examples: X-Y table, Multiple joint robots, Tripod robots

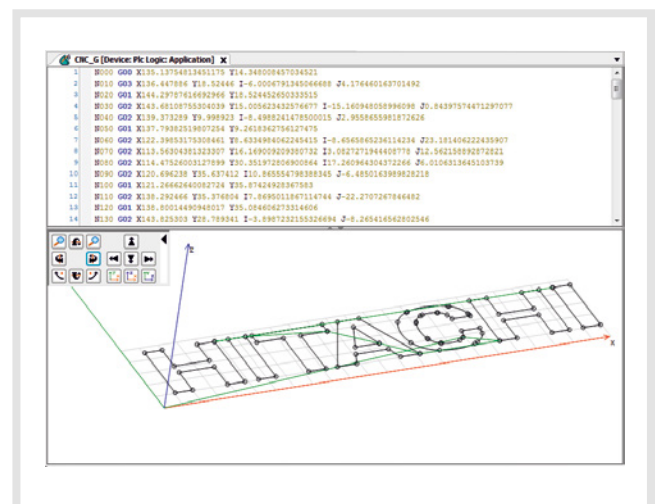

HX Standalone CPU Series

The HX Standalone CPU versions is a dedicated development according to the industrial market demands. Focussing on technology and CPU performance led to a reduced system design to achieve savings in cost and cabinet space.

- Enables the opportunity to use the HX CPU Units without the needs of a separate base rack and power supply
- Up to 3 Ethernet Interfaces for maximum on field connectivity
- Best choice for IoT applications and solutions with no demands on directly connected I/O modularity such as...
 - IoT gateway capability
 - High power and reliable edge computing solution using C/C++
 - Communication master on the field level network
 - Web server and Web Visualization application
 - Powerful Motion Controller using EtherCAT or PROFINET Master Functionality
- Easy integration with less demand on cabinet space
- Use of 24VDC or 12VDC power supply



Standalone Model



Specifications of Standard Features

Item	Standard Model HX-CP1S08 / -0	Full Function Model HX-CP1H16 / -0	Motion Model HX-CP1S08M / -0	CNC Motion Model HX-CP1H16M / -0	Redundant Model HX-CP1H16R	Hybrid Model HXC-CP1H16 / -0	
User program memory	8 MB	16 MB	8 MB		16 MB		
Data memory (non-retain)	8 MB	16 MB	8 MB		16 MB		
Data memory (retain)			0.5 MB			2 MB	
Max. number of expansion bases**	5						
Available expansion cables**	0.5 m, 1 m, 2 m						
Max. expansion distance**	Max. 2 m between bases, total max. 8 m						
Max. number of I/O modules per base**	Max. 11 (excl. power supply module and CPU module)						
Maximum I/O (using 64 point I/O module)**	4,224 I/Os						
Processing time	Bit operation (min.)		1.0 ns				
	Double-precision floating point (min.)		6.6 ns				
Programming languages	IEC61131-3 compliant 5 languages (LD / FBD / SFC / IL / ST) + CFC (Continuous Function Chart)						
C program	Adaptation of C / C++ program		-			✓	
	Data sharing		-			✓	
	Web server for application management		-			✓	
I/O updating cycle	Refresh processing						
Available features	OPC-UA	✓	✓	✓	✓	✓	
	Web visualization	-	✓	-	✓	✓	
	NTP (network time protocol)	✓	✓	✓	✓	✓	
	FTP Server	✓	✓	✓	✓	✓	
	EtherCAT Master	✓	✓	✓	✓	✓	
	(communication cycle)	min. 1ms					
	Modbus-TCP Client/Server	✓	✓	✓	✓	✓	
	Modbus-RTU Master/Slave	✓**	✓	✓**	✓	✓	
	PROFINET Master	✓	✓	✓	✓	✓	
	EtherNet/IP Scanner	✓	✓	✓	✓	✓	
	SoftMotion (PLCopen compliant + CAM editor)	-	-	✓	✓	-	
	CNC (G Codes)	-	-	-	✓	-	
	CPU redundancy	-	-	-	-	✓	
Standard input output interface	Ethernet port	2 ports	3 ports	2 ports	3 ports		
	SD memory card slot	-	✓	-	✓	✓	
	RS-485 Serial comm. port	-	✓	-	✓	✓	
	USB host (USB Memory)	✓	✓	✓	✓	✓	
	USB device (CODESYS protocol)	✓	✓	✓	✓	✓	
Realtime clock	Built-in RTC (deviation ±60 s/month at 25 °C)						
Battery (option for RTC)	HX-BAT (for RTC)						
Maintenance functions	Self-diagnosis (CPU error, Watch-dog timer error, Memory/Battery error, etc.)						

* EH-SIO serial module required

** Not included in Standalone Model

HX Hybrid Series

Hitachi's HX Hybrid CPU has been developed for special applications with a high focus of advanced solutions within the framework of the Industrial Internet of Things. Controlling IT and OT application within one solution enables the best possible use of resources.

HX Controller Hybrid Model adapts to Industrial IoT

- Hybrid Model CPU offers a large range of advanced features and functions to achieve a IoT solution
- Controlling of OT applications with the use of CODESYS V3 runtime while controlling IT applications with the use of 4 independent operating C/C++ programs simultaneously on one hardware
- Shared variable container allows the bi-directional exchange of variables between OT and IT application in real time without interruption of the process
- It allows the adjustment and processing of C/C++ programs in parallel with control program without impact and keep controller operation stable in the control system
- Available as HX Hybrid CPU for base rack usage if an IO system is needed or available as standalone version, if the focus is on the CPU performance for features and functionality

Hardware Architecture

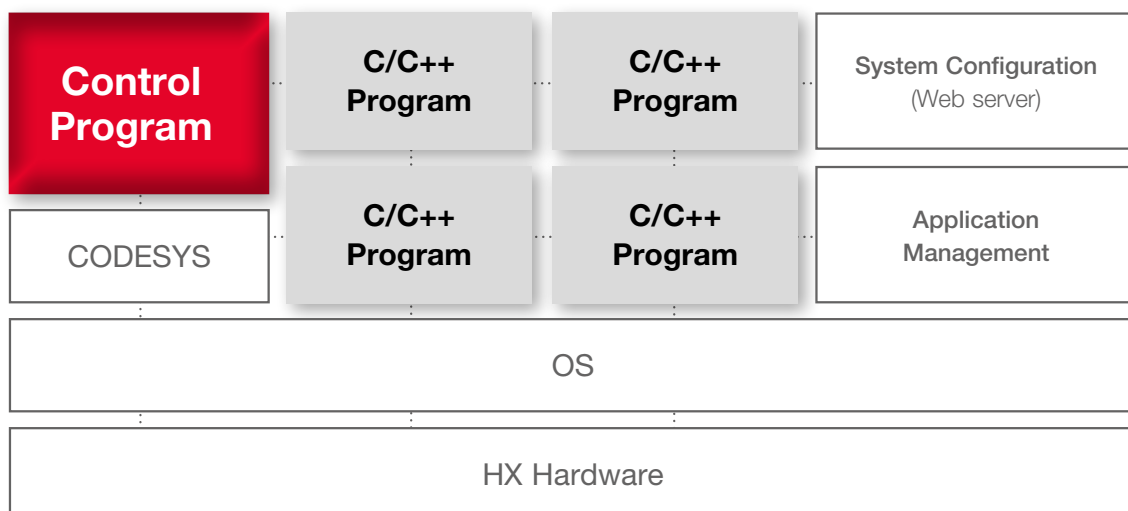



Virtual Controller Information

HITACHI inspire the Next

System Information **Virtual Controller** Shared Memory logout

update

application name	controller image	host name	status	actions
codeysa app	Running	host_codesys	Running	STOP DELETE
fileCreateTest	Running	hx-vcpu1	Running	STOP DELETE
serialTest	stopt	hx-vcpu2	stopt	START DELETE
socketClientTest	Running	hx-vcpu3	Running	STOP DELETE
	Empty	hx-vcpu4	Empty	SETTING DELETE

Please press [Reset] button to re-create virtual controllers, after selecting the number of virtual controllers to be generated.
 Caution: All current virtual controller settings will be cleared.

Current virtual controller number: 4
 Virtual Controller number:



HITACHI inspire the Next

System Information **Virtual Controller** Shared Memory Settings logout

update

Date	Sat Nov 25 21:19:18 UTC 2017
Model	HXC-CP1H16
Kernel	Linux 4.4.62-rt73
Version	DP1.0.5 / WR1.0.4

Memory	total	used	free	shared	buff/cache	available
Mem:	1026992	145452	722484	400	159056	854412
Swap:	0	0	0	0	0	0

Disk	Application	USER	PID	ACPU	%MEM	VSZ	RSS	TTY	STAT	START	TIME	COMMAND
65336		root	1	0.0	0.1	1712	1208	?	S	15:32	0:12	init
		root	2	0.0	0.0	0	0	?	S	15:32	0:00	[kthreadd]
		root	3	0.0	0.0	0	0	?	S	15:32	0:00	[ksoftirqd/0]
		root	4	0.1	0.0	0	0	?	S	15:32	0:33	[ktimeoof/d/0]
		root	5	0.3	0.0	0	0	?	D	15:32	1:19	[kworker/0:0]
		root	6	0.0	0.0	0	0	?	S<	15:32	0:00	[kworker/0:0H]
		root	7	0.0	0.0	0	0	?	S	15:32	0:00	[kworker/u2:0]
		root	8	0.1	0.0	0	0	?	S	15:32	0:24	[rcu_preempt]
		root	9	0.0	0.0	0	0	?	S	15:32	0:00	[rcu_sched]
		root	10	0.1	0.0	0	0	?	S	15:32	0:34	[rcu/0]
		root	11	0.0	0.0	0	0	?	S	15:32	0:00	[kolksetdelayd]
		root	12	0.0	0.0	0	0	?	S	15:32	0:00	[posixcpu/mr/0]
		root	13	0.0	0.0	0	0	?	S	15:32	0:00	[kcomsdelayd]
		root	14	0.0	0.0	0	0	?	S	15:32	0:00	[kdevtmpfs]
		root	15	0.0	0.0	0	0	?	S<	15:32	0:00	[netns]
		root	16	0.0	0.0	0	0	?	S	15:32	0:00	[kswapd]
		root	17	0.0	0.0	0	0	?	S<	15:32	0:00	[perf]
		root	18	0.0	0.0	0	0	?	S	15:32	0:00	[irq/18-13-dbg-1]
		root	19	0.0	0.0	0	0	?	S	15:32	0:00	[irq/19-13-app-1]

HX Series Module List

Item	Model	Specification
Power supply modules	HX-PSA	AC power supply 100–240V, output DC 5V, 3.8A, external DC 24V, 0.4A
	HX-PSD	DC power supply 24V, output DC 5V, 4A, 24V – 0.2A
Base racks	EH-BS3A	Base/Expansion rack with 3 I/O slots
	EH-BS5A	Base/Expansion rack with 5 I/O slots
	EH-BS6A	Base/Expansion rack with 6 I/O slots
	EH-BS8A	Base/Expansion rack with 8 I/O slots
	EH-BS11A	Base/Expansion rack with 11 I/O slots
Input modules	EH-XD8	8 points, DC 24V input, removable terminal block
	EH-XD16	16 points, DC 24V input, removable terminal block
	EH-XD32	32 points, DC 24V input, connector type
	EH-XD32E	32 points, DC 24V input, removable spring type terminal block
	EH-XD64	64 points, DC 24V input, connector type
	EH-XA16	16 points, AC 100–120V input, removable terminal block
	EH-XAH16	16 points, AC 200–240V input, removable terminal block
Output modules	EH-YT8	8 points, transistor output, DC 12/24V, sink type, removable terminal block
	EH-YT16	16 points, transistor output, DC 12/24V, sink type, removable terminal block
	EH-YT32	32 points, transistor output, DC 12/24V, sink type, connector type
	EH-YT32E	32 points, transistor output, DC 12/24V, sink type, removable spring type terminal block
	EH-YT64	64 points, transistor output, DC 12/24V, sink type, connector type
	EH-YTP8	8 points, transistor output, DC 12/24V, source type, removable terminal block
	EH-YTP16	16 points, transistor output, DC 12/24V, source type, removable terminal block
	EH-YTP16S	16 points, transistor output, DC 12/24V, source type, short circuit protection, removable terminal block
	EH-YTP32	32 points, transistor output, DC 12/24V, source type, connector type
	EH-YTP32E	32 points, transistor output, DC 12/24V, source type, removable spring type terminal block
	EH-YTP64	64 points, transistor output, DC 12/24V, source type, connector type
	EH-YR8B	8 points, individual relay output, AC 100/240V, DC 24V, removable terminal block
	EH-YR12	12 points, relay output, AC 100/240V, DC 24V, removable terminal block
	EH-YR16	16 points, relay output, AC 100/240V, DC 24V, 16 points/1common, removable terminal block
	EH-YS16	16 points, triac output, AC 100/240V, removable terminal block

Item	Model	Specification
Analogue input modules	EH-AX44	12 bit analogue input, 4–20 mA, voltage 0–10V, each 4 channel
	EH-AX8V	12 bit analogue input 8 ch., voltage 0 to +10V
	EH-AX8H	12 bit analogue input 8 ch., voltage –10 to +10V
	EH-AX8I	12 bit analogue input 8 ch., current 4–20 mA
	EH-AX8IO	12 bit analogue input 8 ch., current 0–22 mA
	EH-AXH8M	14 bit analogue input 8 channel, 0–22 mA, 4–22 mA, –10 to +10V, 0 to 10V
	EH-AXG5M	Insulation, 16 bit analogue input 5 channel, 0–22 mA, 4–22 mA, –10 to +10V, 0 to 10V
	EH-PT4	4 channel RTD (Pt 100/Pt 1000) input, signed 15 bit
Analogue output modules	EH-RTD8	8/6 channel RTD (Pt 100/Pt 1000) input, signed 15 bit
	EH-TC8	8 channel thermocouple input module (K, E, J, T, B, R, S, N), signed 15 bit
	EH-AY22	12 bit analogue output, 4–20 mA, 0 to 10V, each 2 channel
	EH-AY2H	12 bit analogue output 2 channel, voltage –10 to +10V
Counter modules	EH-AY4V	12 bit analogue output 4 channel, voltage 0 to +10V
	EH-AY4H	12 bit analogue output 4 channel, voltage –10 to +10V
	EH-AY4I	12 bit analogue output 4 channel, current 4–20 mA
	EH-AYH8M	14 bit analogue output 8 channel, 0–22 mA, 4–22 mA, 0 to 10V
	EH-AYG4M	Insulation, 16 bit analogue output 4 channel, 0–22 mA, 4–22 mA, –10 to +10V, 0 to 10V
Positioning module	EH-CU	2channel high speed counter input, max frequency 100 kHz 1/2 phase switchable, 4-point open collector output
	EH-CUE	1 channel high speed counter input, max. frequency 100 kHz 1/2 phase switchable, 2-point open collector output
Communication modules	EH-POS	1axis pulse positioning module, 400k pulse/second
	EH-SIO	Serial communication module (RS-232C/RS-422/485, Modbus protocol)
	EH-RMP2	Profibus-DP master module
	EH-RMD2	DeviceNet scanner module
Dummy module	EH-LNK	CPU link module, coaxial cable
	EH-DUM	Module for open slots

Hitachi Europe GmbH, Niederkasseler Lohweg 191, D-40547 Düsseldorf
 Phone: +49 (0) 211-5283-0
 www.hitachi-industrial.eu, automation.industrial@hitachi-eu.com
 © Hitachi Industrial Equipment Systems Co., Ltd., Japan

All company and product names in this brochure are the property of the respective companies.

Hitachi Industrial Equipment Systems Co., Ltd. (Hitachi) shall not be liable for any manufacturing loss, or any product damage due to trouble. Hitachi continually improves products. The right, therefore, is reserved to alter the designs and/or specifications without giving prior notice. Information in this brochure is subject to change without notice.